

SHEET1

Rev:	Date:	By	Chk	Description
A.1	9/18/12	PJE	RAW	EC0 0045
A.2	10/06/12	JWW	PJE	EC0 0192

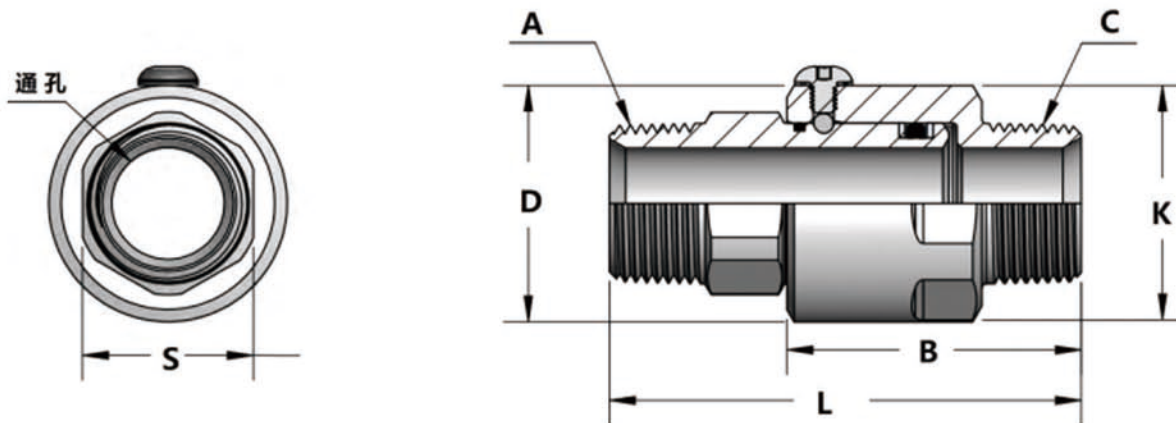

	A	B	C	D	K	L	S	压力 MPa	转速 RPM
MNA-C08	R1/4"	40	R1/4"	25	20	60	20	7.0	30
MNA-C10	R3/8"	42	R3/8"	32	28	63	25	7.0	30
MNA-C15	R1/2"	45	R1/2"	38	32	75	28	5.0	20
MNA-C20	R3/4"	48	R3/4"	42	38	78	35	4.0	20
MNA-C25	R1"	60	R1"	48	44	97	42	4.0	15
MNA-C32	R1-1/4"	66	R1-1/4"	60	53	103	51	4.0	10
MNA-C40	R1-1/2"	79	R1-1/2"	65	61	122	60	4.0	10
MNA-C50	R2"	93	R2"	76	73	133	73	2.5	5

技术参数：
 最高转速：30RPM
 最高温度：125°C
 最大压力：70BAR
 介质：液压油 气 水

Drawn	JSM	6/2/03
Checked	PJE	13/43/05
Checked	PJE	11/36/08

TOLERANCE
 EXCEPT AS NOTED
 x.x ±.125
 x.xx ± 0.15
 x.xxx ± 0.005
 ANGLES ± 0.5°

HIDNEY

深圳市欣德利机电设备有限公司

TEL:0755-27222664

CUSTOMER APPROVAL/DATE:

SHAFT MEL/PLTING:
 CARBON STL
 94-62 RC
 BLK OXIDE

CUSTOMER:
 STOCK

THIS DOCUMENT CONTAINS INFORMATION WHICH IS PROPRIETARY TO DYNAMIC SEALING TECHNOLOGIES, INC. (HIDNEY) NO REPRODUCTION OR PUBLICATION OF THIS DOCUMENT OR IT IS CONTENTS, IN SHOLE OR PART SHALL BE MADE WITHOUT THE WRITTEN CONSENT FROM HIDNEY

SHAFT MEL/PLTING:
 CARBON STL
 BLK OXIDE

P/N:
 REV:
 A 4

THIRD ANGLE PROJECTION:

